



**USA
SLIDING
DOORS**

43676 Progress Way, Chilliwack, BC V2R 0C3
604.607.0091 | **Toll Free:** 1.800.770.0455
info@advantecglobal.com | usaslidingdoors.com

Double Electro-Hydraulic Cargo Door

Model Number: USA-1005

Dual electro-hydraulic sliding cargo door, watertight to 22' head pressure.

*Custom sizes and pressures available upon request.

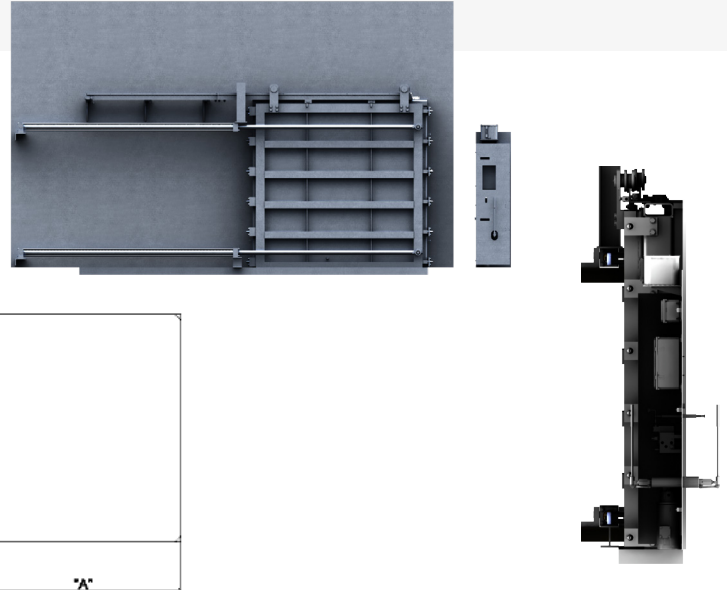

RATING: WT

CLEAR OPENING SIZE:

Tolerance $\pm 1/8$ "

	Min	Max
"A"	78"	90"
"B"	78"	102"

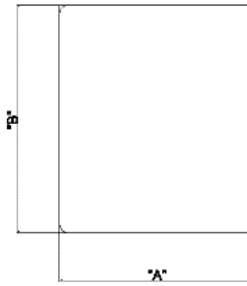

POWER REQUIREMENTS:

- 460VAC, 60Hz, 30A, 3 Phase
(AVG: 4 kW)

WEIGHT:

- Approx.: 2240 LB.

MINIMUM CLOSING TIME:

- TBD

FRAME FINISH OPTIONS:

- Bare Metal, Mill Finish
- Primer Paint
- Primer Base Coats
- Topcoat
- Powder Coat

OF DOG PINS:

- 12

DOOR MATERIAL:

- Mild Steel
- Aluminum

FRAME MATERIAL:

- Mild Steel
(For Steel Door Only)
- Aluminum
(For Aluminum Door Only)

GASKET:

- Neoprene

ACTUATION:

- Dual Hydraulic (3000 PSI
Test/750 PSI Operation)

SAFETY FEATURES:

- Hazard Lights
- Hazard Buzzer

OPERATION:

- Manual (Hand Lever)
- Electrically Powered
- Locally Operated
- Bridge Controlled

CLASS OPTIONS:

(Vessel type and size rule set typically reviewed for Class)

- ABS
- DNV-GL
- LR

AVAILABLE DOCUMENTS:

- Wiring Diagrams
- Installation Manual



PROUDLY MADE IN
NORTH AMERICA

ISO 9001