

SECTION B-B WITH CLAMP IN INSTALLATION

ITEMS			
ID	DESCRIPTION	MATERIAL	PART NUMBER
1	MOUNTING FRAME	6063 ALUMINUM	103818
2	GLAZING	GLASS 6mm (1/4") TO 10mm (3/8")	VARIES
3	GASKET	EPDM	103023
4	BUTYL TAPE		103012
5	SEALANT	SILICONE	
6	TRIM RING	6063 ALUMINUM	VARIES
7	TRIM SCREWS	S.S.	
8	BEDDING COMPOUND	CUSTOMER TO SUPPLY	N/A
9	BACKFILL	URETHANE	
10	HINGED LITE GLAZING	SANTOPRENE	103057
11	106 FLIP OUT	6063 ALUMINUM	103826

STANDARD DIMENSIONS		
ID	DESCRIPTION	DIMENSION
A	FLANGE COVERAGE	20mm (7/8")
B	EXTERIOR PROTRUSION	16mm (5/8")
C	INTERIOR PROTRUSION	35mm (1 3/8")
D	SPIGOT TO CLEAR OPEN	38 mm (1 1/2")
E	FLANGE THICKNESS	3mm (1/8")

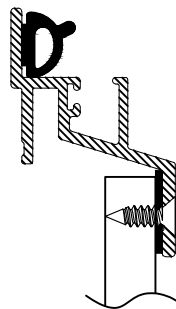

OPTIONAL BOLT-ON INSTALLATION

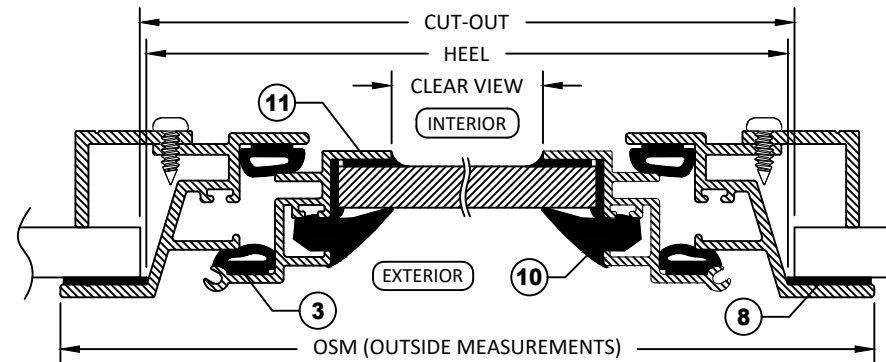
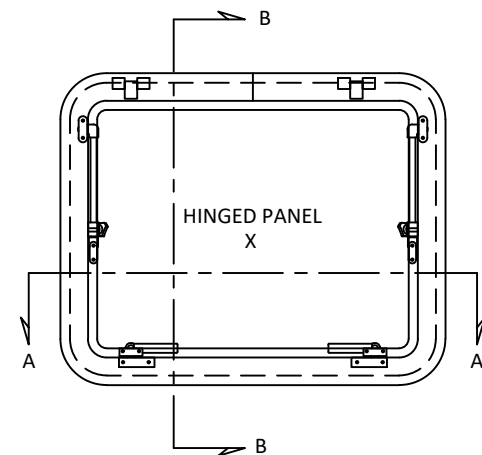

SECTION A-A WITH CLAMP IN INSTALLATION

NOTES:

- GENERAL HEEL TOLERANCE +0/-1/4" OVERALL
- AVAILABLE WITH 3"(76MM) OR MITERED CORNERS
- STANDARD MOUNTING HOLES ARE 3/16" WITH #10 COUNTERSUNK ON 6" NOMINAL CENTERS
- CAM HANDLES AND ADJUSTERS NOT SHOWN IN X-SECTION
- GLAZING OPTIONS: 6mm TO 10mm GLASS
- INSTALLATION: BOLT IN OR CLAMP RING (Z OR L PROFILE)

DRAWING NUMBER

106TH

SCALE

NTS

BY

LD

DIAMOND SEA GLAZE MANUFACTURING LTD.  
26995 GLOUCESTER WAY, LANGLEY B.C.  
CANADA V4W 3Y3  
TOLL FREE: 1-800-770-0455  
PHONE: 604-607-0091  
FAX: 604-607-0092

C:\Documents and Settings\jharmon\Quoting\SSG PDF Log.ppt

ITEM NAME

106TH

ITEM DESCRIPTION

HINGED OPENING WINDOW

ALL DRAWINGS AND ANY ASSOCIATED INFORMATION HEREON CONTAIN PROPRIETARY AND/OR CONFIDENTIAL INFORMATION, AND SHALL NOT BE REPRODUCED, DISCLOSED OR SUBMITTED TO ANY THIRD PARTY WITHOUT PRIOR CONSENT FROM DIAMOND SEA GLAZE MANUFACTURING LTD.